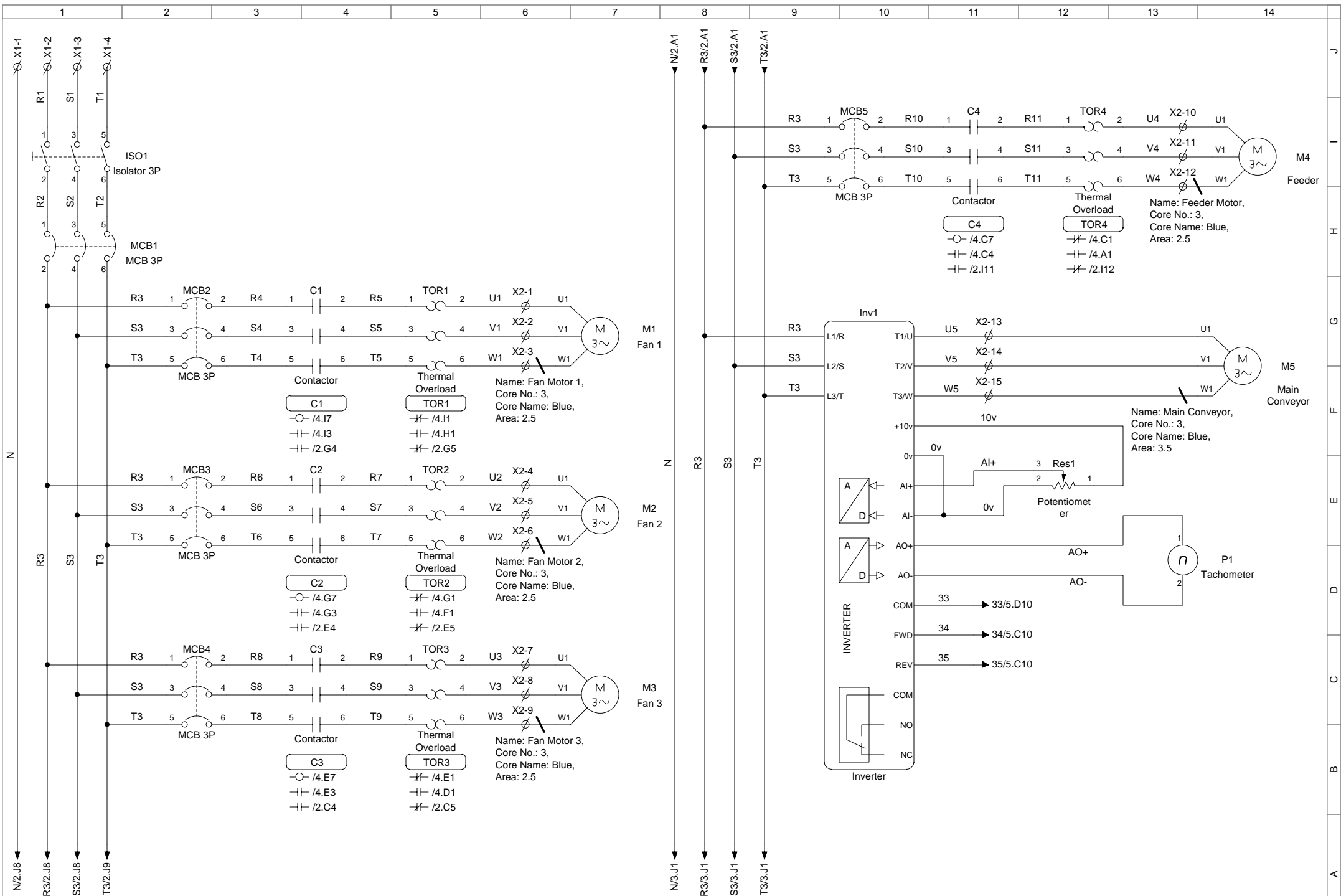
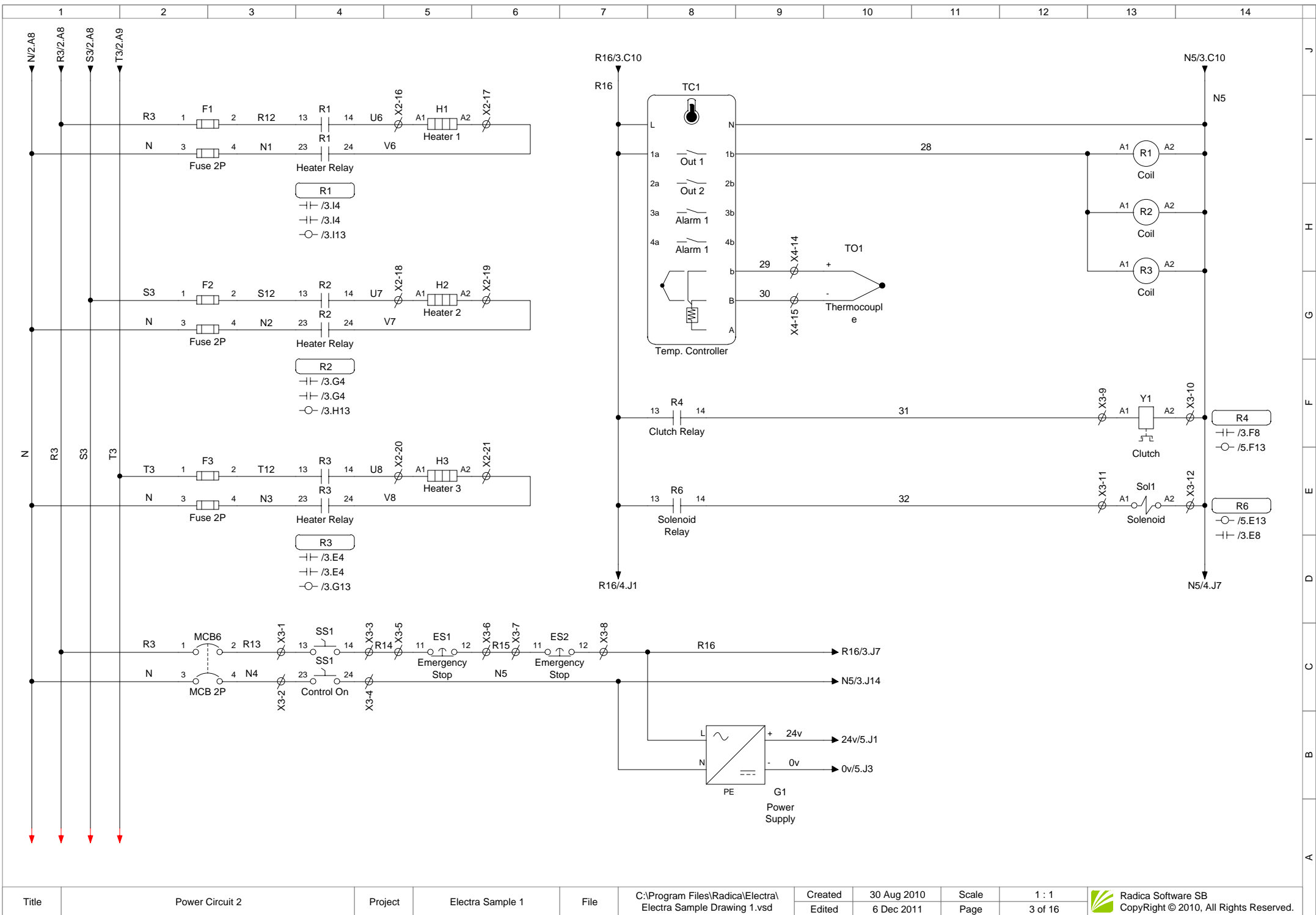
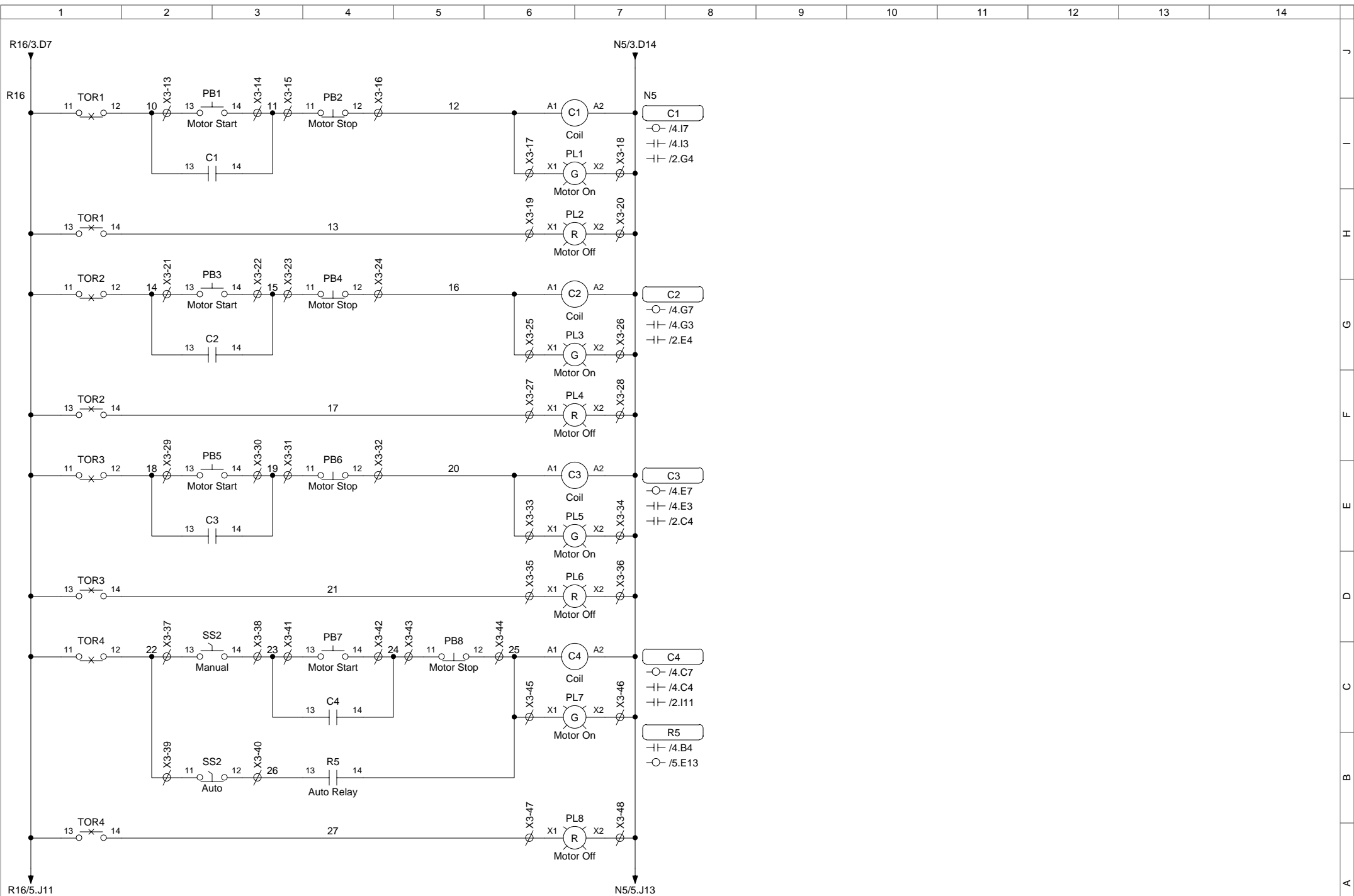



Table of Contents		
Item	Title	Page
1	Table Of Contents	1
2	Power Circuit 1	2
3	Power Circuit 2	3
4	Fan Control Circuits	4
5	PLC Circuits	5
6	Terminal Layout	6
7	Layout	7
8	Front Panel Layout	8
9	Cross Reference Report	9
10	Material Reference Report	10
11	Bills Of Materials Report	11
12	Cable Reference Report	12
13	Cable Reference Report 2	13
14	Connection Report	14
15	Connection Report	15
16	Connection Report	16

J
I
H
G
F
E
D
C
B
A







Title	Fan Control Circuits	Project	Electra Sample 1	File	C:\Program Files\Radica\Electra\Electra Sample Drawing 1.vsd	Created	30 Aug 2010	Scale	1 : 1	 Radica Software SB Copyright © 2010, All Rights Reserved.
						Edited	6 Dec 2011	Page	4 of 16	

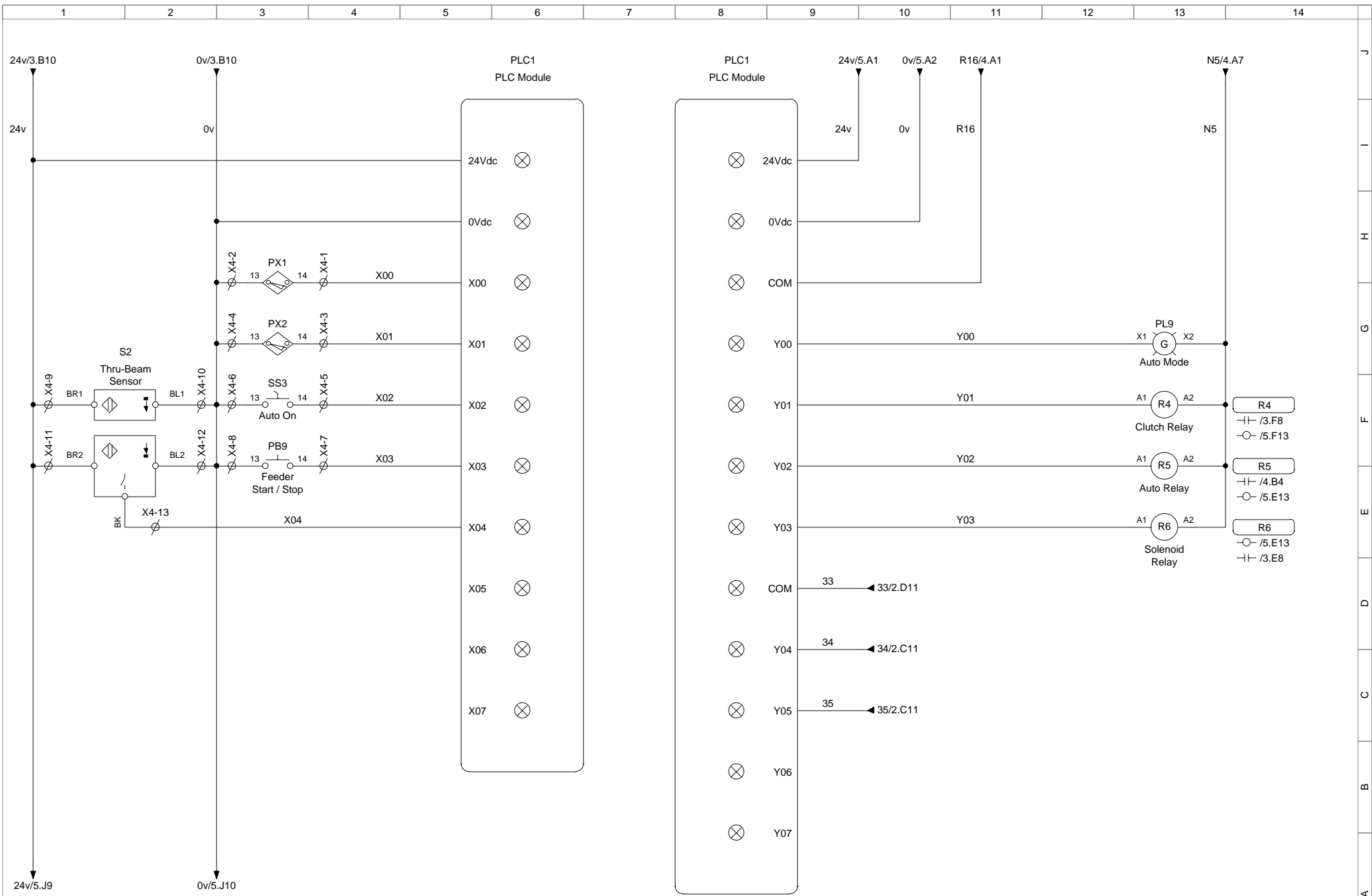

X1	X1-1	N
	X1-2	R1
	X1-3	S1
	X1-4	T1

Qty: 4

X2	X2-1	U1
	X2-2	V1
	X2-3	W1
	X2-4	U2
	X2-5	V2
	X2-6	W2
	X2-7	U3
	X2-8	V3
	X2-9	W3
	X2-10	U4
	X2-11	V4
	X2-12	W4
	X2-13	U5
	X2-14	V5
	X2-15	W5
	X2-16	U6
	X2-17	V6
	X2-18	W7
	X2-19	U8
	X2-20	V8
	X2-21	W8

Qty: 21

X3	X3-1	R13
	X3-2	N4
	X3-3	R14
	X3-4	N5
	X3-5	R14
	X3-6	R15
	X3-7	R15
	X3-8	R16
	X3-9	31
	X3-10	N5
	X3-11	32
	X3-12	N5
	X3-13	10
	X3-14	11
	X3-15	11
	X3-16	12
	X3-17	12
	X3-18	N5
	X3-19	13
	X3-20	N5
	X3-21	14
	X3-22	15
	X3-23	15
	X3-24	16
	X3-25	16
	X3-26	N5
	X3-27	17
	X3-28	N5
	X3-29	18
	X3-30	19
	X3-31	19
	X3-32	20
	X3-33	N5
	X3-34	21
	X3-35	N5
	X3-36	22
	X3-37	23
	X3-38	22
	X3-39	26
	X3-40	23
	X3-41	24
	X3-42	24
	X3-43	25
	X3-44	25
	X3-45	N5
	X3-46	27
	X3-47	N5
	X3-48	N5

Qty: 48

X4	X4-1	X00
	X4-2	0v
	X4-3	X01
	X4-4	0v
	X4-5	X02
	X4-6	0v
	X4-7	X03
	X4-8	0v
	X4-9	24v
	X4-10	0v
	X4-11	24v
	X4-12	0v
	X4-13	X04
	X4-14	29
	X4-15	30

Qty: 15

J
I
H
G
F
E
D
C
B
A

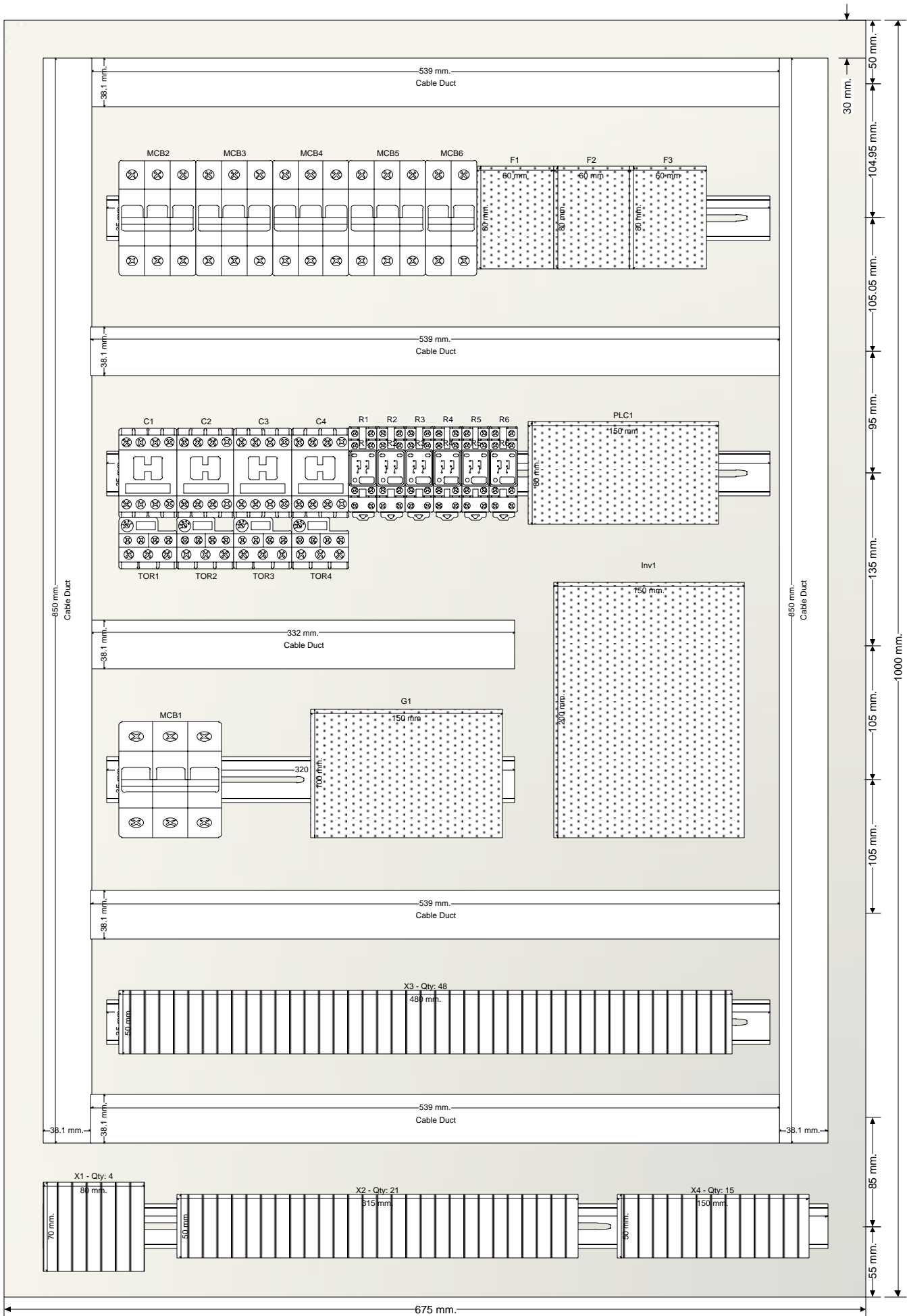

N
M
L
K
J
I
H
G
F
E
D
C
B
A

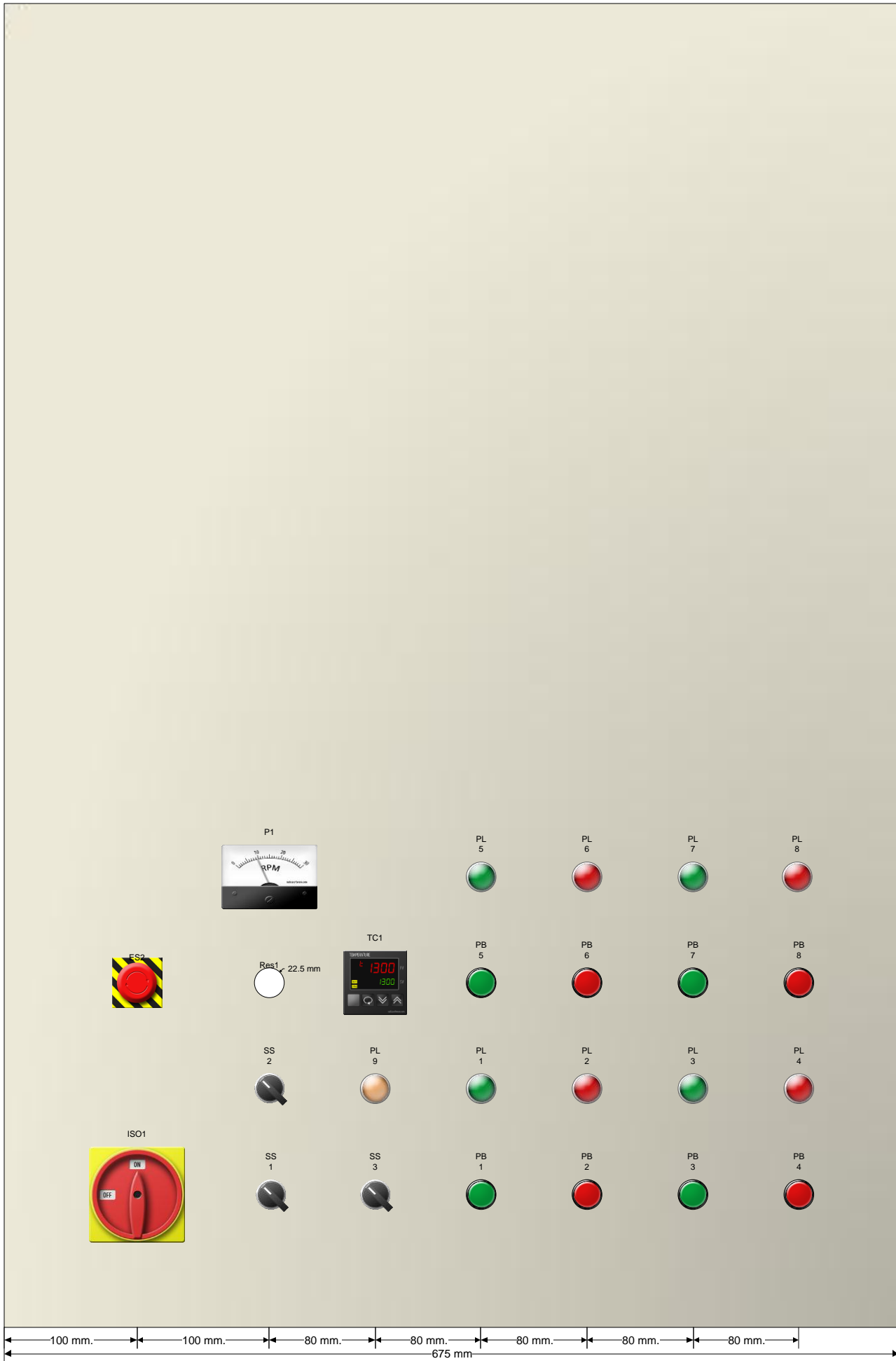

N
M
L
K
J
I
H
G
F
E
D
C
B
A

Reference	Description	Master	Location
C1	NO Contact	Normally Open Contact	/4.I2
C1	Coil	Coil	/4.I6
C1	Contactora	Contactora	/2.G4
C2	NO Contact	Normally Open Contact	/4.G2
C2	Coil	Coil	/4.G6
C2	Contactora	Contactora	/2.E4
C3	NO Contact	Normally Open Contact	/4.E2
C3	Coil	Coil	/4.E6
C3	Contactora	Contactora	/2.C4
C4	NO Contact	Normally Open Contact	/4.C4
C4	Coil	Coil	/4.C6
C4	Contactora	Contactora	/2.I11
ES1	Emergency Stop	Emergency Stop NC	/3.C5
ES2	Emergency Stop	Emergency Stop NC	/3.C6
F1	Fuse 2P	Fuse 2P	/3.I2
F2	Fuse 2P	Fuse 2P	/3.G2
F3	Fuse 2P	Fuse 2P	/3.E2
G1	Power Supply	Power Supply, Rectifier - AC/DC	/3.B8
H1	Heater 1	Heater	/3.I5
H2	Heater 2	Heater	/3.G5
H3	Heater 3	Heater	/3.E5
ISO1	Isolator 3P	Isolator 3P	/2.I1
Inv1	Inverter	Inverter	/2.D10
M1	Fan 1	AC Motor 3P - 3 Terminal	/2.G7
M2	Fan 2	AC Motor 3P - 3 Terminal	/2.E7
M3	Fan 3	AC Motor 3P - 3 Terminal	/2.C7
M4	Feeder	AC Motor 3P - 3 Terminal	/2.I14
M5	Main Conveyor	AC Motor 3P - 3 Terminal	/2.F14
MCB1	MCB 3P	Circuit Breaker 3P	/2.H1
MCB2	MCB 3P	Circuit Breaker 3P	/2.G2
MCB3	MCB 3P	Circuit Breaker 3P	/2.E2
MCB4	MCB 3P	Circuit Breaker 3P	/2.C2
MCB5	MCB 3P	Circuit Breaker 3P	/2.I10
MCB6	MCB 2P	Circuit Breaker 2P	/3.C2
P1	Tachometer	Tachometer	/2.D13
PB1	Motor Start	Push Button NO	/4.I2
PB2	Motor Stop	Push Button NC	/4.I4
PB3	Motor Start	Push Button NO	/4.G2
PB4	Motor Stop	Push Button NC	/4.G4
PB5	Motor Start	Push Button NO	/4.E2
PB6	Motor Stop	Push Button NC	/4.E4
PB7	Motor Start	Push Button NO	/4.C4
PB8	Motor Stop	Push Button NC	/4.C5
PB9	Feeder Start / Stop	Push Button NO	/5.E3
PL1	Motor On	Pilot Light	/4.I6
PL2	Motor Off	Pilot Light	/4.H6
PL3	Motor On	Pilot Light	/4.G6
PL4	Motor Off	Pilot Light	/4.F6
PL5	Motor On	Pilot Light	/4.E6
PL6	Motor Off	Pilot Light	/4.D6
PL7	Motor On	Pilot Light	/4.C6
PL8	Motor Off	Pilot Light	/4.A6
PL9	Auto Mode	Pilot Light	/5.G13
PLC1	PLC Module	PLC Module	/5.E8
PLC1	PLC Module	PLC Module	/5.F6
PX1	Proximity Switch	Proximity Switch NO	/5.G3
PX2	Proximity Switch	Proximity Switch NO	/5.G3
R1	Coil	Coil	/3.I13
R1	Heater Relay	Normally Open Contact	/3.I4
R1	Heater Relay	Normally Open Contact	/3.I4
R2	Coil	Coil	/3.H13
R2	Heater Relay	Normally Open Contact	/3.G4
R2	Heater Relay	Normally Open Contact	/3.G4
R3	Coil	Coil	/3.G13
R3	Heater Relay	Normally Open Contact	/3.E4
R3	Heater Relay	Normally Open Contact	/3.E4
R4	Clutch Relay	Coil	/5.F13
R4	Clutch Relay	Normally Open Contact	/3.F8

Reference	Description	Master	Location
R5	Auto Relay	Coil	/5.E13
R5	Auto Relay	Normally Open Contact	/4.B4
R6	Solenoid Relay	Coil	/5.E13
R6	Solenoid Relay	Normally Open Contact	/3.E8
Res1	Potentiometer	Potentiometer	/2.E12
SS2	Thru-Beam Sensor	Photoelectric Sensor - Through Beam,	/5.F2
SS1	Control On	Both	/3.C4
SS1	Control On	Selector Switch NO	/3.C4
SS2	Auto	Selector Switch NO	/4.B2
SS2	Manual	Selector Switch NC	/4.C2
SS3	Auto On	Selector Switch NO	/5.F3
So1	Solenoid	Selector Switch NO	/3.E13
TC1	Temp. Controller	Solenoid	/3.H8
TO1	Thermocouple	Temperature Controller	/3.G10
TOR1	Thermal Overload	Thermocouple	/4.H1
TOR1	Thermal Overload	Thermal Overload NO	/4.I1
TOR1	Thermal Overload	Thermal Overload NC	/2.G5
TOR2	Thermal Overload	Thermal Overload	/4.F1
TOR2	Thermal Overload	Thermal Overload NO	/4.G1
TOR2	Thermal Overload	Thermal Overload NC	/2.E5
TOR3	Thermal Overload	Thermal Overload	/4.D1
TOR3	Thermal Overload	Thermal Overload NO	/4.E1
TOR3	Thermal Overload	Thermal Overload NC	/2.C5
TOR4	Thermal Overload	Thermal Overload	/4.A1
TOR4	Thermal Overload	Thermal Overload NO	/4.C1
TOR4	Thermal Overload	Thermal Overload NC	/2.I12
Y1	Clutch	Thermal Overload	/3.F13
		Magnetic Clutch	

Reference	Component Name	Description	Brand	Rating	Model	Quantity
C1	Contactora 3P		Generic			1
C2	Contactora 3P		Generic			1
C3	Contactora 3P		Generic			1
C4	Contactora 3P		Generic			1
ES1	Emergency Stop - Turn Reset	Push lock, Turn Reset	Generic			1
ES2	Emergency Stop - Turn Reset	Push lock, Turn Reset	Generic			1
F1	Fuse 2P		Generic			1
F2	Fuse 2P		Generic			1
F3	Fuse 2P		Generic			1
G1	Power Supply AC/DC - Switching	Switching Power Supply	Generic			1
H1	Heater	Heater	Generic			1
H2	Heater	Heater	Generic			1
H3	Heater	Heater	Generic			1
ISO1	Isolator/Disconnecter 3P	Panel Mount	Generic			1
Inv1	Inverter	Motor Inverter	Generic			1
M1	Motor 3P AC		Generic			1
M2	Motor 3P AC		Generic			1
M3	Motor 3P AC		Generic			1
M4	Motor 3P AC		Generic			1
M5	Motor 3P AC		Generic			1
MCB1	MCB 3P	Miniature Circuit Breaker	Generic			1
MCB2	MCB 3P	Miniature Circuit Breaker	Generic			1
MCB3	MCB 3P	Miniature Circuit Breaker	Generic			1
MCB4	MCB 3P	Miniature Circuit Breaker	Generic			1
MCB5	MCB 3P	Miniature Circuit Breaker	Generic			1
MCB6	MCB 2P	Miniature Circuit Breaker Double Pole	Generic			1
P1	Tachometer		Generic			1
PB1	Push Button - Momentary	Spring Return	Generic			1
PB2	Push Button - Momentary	Spring Return	Generic			1
PB3	Push Button - Momentary	Spring Return	Generic			1
PB4	Push Button - Momentary	Spring Return	Generic			1
PB5	Push Button - Momentary	Spring Return	Generic			1
PB6	Push Button - Momentary	Spring Return	Generic			1
PB7	Push Button - Momentary	Spring Return	Generic			1
PB8	Push Button - Momentary	Spring Return	Generic			1
PB9	Push Button - Momentary	Spring Return	Generic			1
PL1	Pilot Light		Generic			1
PL2	Pilot Light		Generic			1
PL3	Pilot Light		Generic			1
PL4	Pilot Light		Generic			1
PL5	Pilot Light		Generic			1
PL6	Pilot Light		Generic			1
PL7	Pilot Light		Generic			1
PL8	Pilot Light		Generic			1
PL9	Pilot Light		Generic			1
PLC1	PLC Module		Generic			1
PX1	Proximity Switch		Generic			1
PX2	Proximity Switch		Generic			1
R1	Relay - MY2/MY4	MY2/MY4	Generic			1
R1	Relay Base 2P		Generic			1
R2	Relay - MY2/MY4	MY2/MY4	Generic			1
R2	Relay Base 2P		Generic			1
R3	Relay - MY2/MY4	MY2/MY4	Generic			1
R3	Relay Base 2P		Generic			1
R4	Relay - MY2/MY4	MY2/MY4	Generic			1
R4	Relay Base 2P		Generic			1
R5	Relay - MY2/MY4	MY2/MY4	Generic			1
R5	Relay Base 2P		Generic			1
R6	Relay - MY2/MY4	MY2/MY4	Generic			1
R6	Relay Base 2P		Generic			1
Res1	Potentiometer		Generic			1
S2	Photoelectric Sensor - Through Beam, Both	Through Beam, Transmitter & Receiver Set	Generic			1
SS1	Selector Switch 2 Pos - Maintained	Maintained	Generic			1
SS2	Selector Switch 2 Pos - Maintained	Maintained	Generic			1
SS3	Selector Switch 2 Pos - Maintained	Maintained	Generic			1
Sol1	Solenoid		Generic			1
TC1	Temperature Controller		Generic			1
TO1	Thermocouple		Generic			1
TOR1	Thermal Overload Relay		Generic			1
TOR2	Thermal Overload Relay		Generic			1

Reference	Component Name	Description	Brand	Rating	Model	Quantity
TOR3	Thermal Overload Relay		Generic			1
TOR4	Thermal Overload Relay		Generic			1
Y1	Clutch		Generic			1

Component Name	Description	Brand	Rating	Model	Quantity	Price	Amount
Cable Duct	(W x H) 332.0000 mm x 38.1000 mm	Generic			1	0.00	0.00
Cable Duct	(W x H) 539.0000 mm x 38.1000 mm	Generic			4	0.00	0.00
Cable Duct	(W x H) 850.0000 mm x 38.1000 mm	Generic			2	0.00	0.00
Clutch		Generic			1	0.00	0.00
Contactor 3P		Generic			4	0.00	0.00
DIN Rail	(W x H) 320.0000 mm x 35.0000 mm	Generic			1	0.00	0.00
DIN Rail	(W x H) 520.0000 mm x 35.0000 mm	Generic			3	0.00	0.00
DIN Rail	(W x H) 615.0000 mm x 35.0000 mm	Generic			1	0.00	0.00
Emergency Stop - Turn Reset	Push lock, Turn Reset	Generic			2	0.00	0.00
Fuse 2P		Generic			3	0.00	0.00
Heater	Heater	Generic			3	0.00	0.00
Inverter	Motor Inverter	Generic			1	0.00	0.00
Isolator/Disconnecter 3P	Panel Mount	Generic			1	0.00	0.00
MCB 2P	Miniature Circuit Breaker Double Pole	Generic			1	0.00	0.00
MCB 3P	Miniature Circuit Breaker	Generic			5	0.00	0.00
Motor 3P AC		Generic			5	0.00	0.00
PLC Module		Generic			1	0.00	0.00
Photoelectric Sensor - Through Beam, Both	Through Beam, Transmitter & Receiver Set	Generic			1	0.00	0.00
Pilot Light		Generic			9	0.00	0.00
Potentiometer		Generic			1	0.00	0.00
Power Supply AC/DC - Switching	Switching Power Supply	Generic			1	0.00	0.00
Proximity Switch		Generic			2	0.00	0.00
Push Button - Momentary	Spring Return	Generic			9	0.00	0.00
Relay - MY2/MY4	MY2/MY4	Generic			6	0.00	0.00
Relay Base 2P		Generic			6	0.00	0.00
Selector Switch 2 Pos - Maintained	Maintained	Generic			3	0.00	0.00
Solenoid		Generic			1	0.00	0.00
Tachometer		Generic			1	0.00	0.00
Temperature Controller		Generic			1	0.00	0.00
Terminal	(W x H) 10.0000 mm x 50.0000 mm	Generic	10A		63	0.00	0.00
Terminal	(W x H) 15.0000 mm x 50.0000 mm	Generic	10A		21	0.00	0.00
Terminal	(W x H) 20.0000 mm x 70.0000 mm	Generic	30A		4	0.00	0.00
Thermal Overload Relay		Generic			4	0.00	0.00
Thermocouple		Generic			1	0.00	0.00
Sub/Total:					173/173	Sub/Total:	0.00/0.00

J
I
H
G
F
E
D
C
B
A

Cable	Core Name	Wire	Location
Name: Fan Motor 1 Brand: Generic Model: Generic Cores: 3 Area: 2.5 Order No.: Supplier: Remarks: Price: 0	Red Yellow Blue	U1 V1 W1	/2.G6 /2.G6 /2.F6
Name: Fan Motor 2 Brand: Generic Model: Generic Cores: 3 Area: 2.5 Order No.: Supplier: Remarks: Price: 0	Red Yellow Blue	U2 V2 W2	/2.E6 /2.E6 /2.D6
Name: Fan Motor 3 Brand: Generic Model: Generic Cores: 3 Area: 2.5 Order No.: Supplier: Remarks: Price: 0	Red Yellow Blue	U3 V3 W3	/2.C6 /2.C6 /2.B6
Name: Feeder Motor Brand: Generic Model: Generic Cores: 3 Area: 2.5 Order No.: Supplier: Remarks: Price: 0	Red Yellow Blue	U4 V4 W4	/2.I13 /2.I13 /2.H13
Name: Main Conveyor Brand: Generic Model: Generic Cores: 3 Area: 3.5 Order No.: Supplier: Remarks: Price: 0	Red Yellow Blue	U5 V5 W5	/2.G12 /2.F12 /2.F12
Name: 1 Core Brand: Generic Model: Generic Cores: 1 Area: 2.5 Order No.: Supplier: Remarks: Price: 0	1	U6	/3.I5
Name: 1 Core Brand: Generic Model: Generic Cores: 1 Area: 2.5 Order No.: Supplier: Remarks: Price: 0	1	V6	/3.I6

Cable	Core Name	Wire	Location
Name: 1 Core Brand: Generic Model: Generic Cores: 1 Area: 2.5 Order No.: Supplier: Remarks: Price: 0	1	U7	/3.G5
Name: 1 Core Brand: Generic Model: Generic Cores: 1 Area: 2.5 Order No.: Supplier: Remarks: Price: 0	1	V7	/3.G6
Name: 1 Core Brand: Generic Model: Generic Cores: 1 Area: 2.5 Order No.: Supplier: Remarks: Price: 0	1	U8	/3.E5
Name: 1 Core Brand: Generic Model: Generic Cores: 1 Area: 2.5 Order No.: Supplier: Remarks: Price: 0	1	V8	/3.E6
Name: 1 Core Brand: Generic Model: Generic Cores: 1 Area: 2.5 Order No.: Supplier: Remarks: Price: 0	1	N5	/3.F14
Name: 1 Core Brand: Generic Model: Generic Cores: 1 Area: 2.5 Order No.: Supplier: Remarks: Price: 0	1	31	/3.F13
Name: 1 Core Brand: Generic Model: Generic Cores: 1 Area: 2.5 Order No.: Supplier: Remarks: Price: 0	1	N5	/3.E14

Cable	Core Name	Wire	Location
Name: 1 Core Brand: Generic Model: Generic Cores: 1 Area: 2.5 Order No.: Supplier: Remarks: Price: 0	1	32	/3.E13
Name: Default Cable Brand: Generic Model: Generic Cores: 1 Area: 1.5 Order No.: Supplier: Remarks: Price: 0		AI+ AO+ AO- N N R1 R2 R3 R3 R3 R3 R3 R3 R3 R4 R5 R6 R7 R8 R9 R10 R11 S1 S2 S3 S3 S3 S3 S3 S3 S4 S5 S6 S7 S8 S9 S10 S11 T1 T2 T3 T3 T3 T3 T3 T4 T5 T6 T7 T8 T9 T10 T11 U1 U2 U3 U4	/2.E11 /2.E12 /2.D12 /2.E8 /2.F1 /2.J1 /2.H1 /2.I9 /2.C1 /2.E1 /2.G1 /2.G9 /2.E8 /2.D1 /2.G3 /2.G4 /2.E3 /2.E4 /2.C3 /2.C4 /2.I10 /2.I12 /2.J1 /2.H1 /2.I9 /2.C1 /2.E1 /2.G1 /2.G9 /2.E8 /2.D1 /2.G3 /2.G4 /2.E3 /2.E4 /2.C3 /2.C4 /2.I10 /2.I12 /2.J1 /2.H1 /2.H9 /2.C2 /2.E2 /2.G2 /2.F9 /2.E9 /2.D1 /2.G3 /2.G4 /2.E3 /2.D4 /2.C3 /2.B4 /2.H10 /2.H12 /2.G6 /2.E6 /2.C6 /2.I13

Cable	Core Name	Wire	Location
		U5	/2.G11
		V1	/2.G6
		V2	/2.E6
		V2	/2.E6
		V3	/2.C6
		V4	/2.I13
		V5	/2.G11
		W1	/2.F6
		W2	/2.D6
		W3	/2.B6
		W4	/2.H13
		W5	/2.F11
		0v	/2.E11
		0v	/2.E10
		10v	/2.F11
		33	/2.D11
		34	/2.D11
		35	/2.C11
		N	/3.E1
		N	/3.C1
		N	/3.E1
		N	/3.G1
		N	/3.I1
		N1	/3.I3
		N2	/3.G3
		N3	/3.E3
		N4	/3.C3
		N5	/3.E14
		N5	/3.D14
		N5	/3.G14
		N5	/3.H14
		N5	/3.I14
		N5	/3.I14
		N5	/3.I11
		N5	/3.B8
		N5	/3.C7
		R3	/3.E1
		R3	/3.C1
		R3	/3.I1
		R12	/3.I3
		R13	/3.C3
		R14	/3.C4
		R15	/3.C6
		R16	/3.E7
		R16	/3.E7
		R16	/3.C8
		R16	/3.G7
		R16	/3.I7
		R16	/3.I7
		R16	/3.B8
		S3	/3.E1
		S3	/3.G2
		S12	/3.G3
		T3	/3.E1
		T3	/3.E2
		T12	/3.E3
		U6	/3.I4
		U7	/3.G4
		U8	/3.E4
		V6	/3.I5
		V7	/3.G5
		V8	/3.E5
		0v	/3.B9
		24v	/3.B9
		28	/3.H13
		28	/3.I13
		28	/3.I11
		29	/3.H9
		29	/3.H9

Name: Default Cable
 Brand: Generic
 Model: Generic
 Cores: 1
 Area: 1.5
 Order No.:
 Supplier:
 Remarks:
 Price: 0

Cable	Core Name	Wire	Location
		30	/3.G9
		30	/3.G9
		31	/3.F10
		32	/3.E10
		N5	/4.A7
		N5	/4.B7
		N5	/4.C7
		N5	/4.D7
		N5	/4.F7
		N5	/4.D7
		N5	/4.E7
		N5	/4.H7
		N5	/4.F7
		N5	/4.G7
		N5	/4.H7
		N5	/4.I7
		R16	/4.A1
		R16	/4.B1
		R16	/4.D1
		R16	/4.F1
		R16	/4.E1
		R16	/4.H1
		R16	/4.G1
		R16	/4.I1
		R16	/4.J1
		10	/4.I2
		10	/4.I2
		11	/4.I3
		11	/4.I3
		12	/4.I6
		12	/4.I5
		13	/4.H4
		14	/4.G2
		14	/4.G2
		15	/4.G3
		15	/4.G3
		16	/4.G6
		16	/4.G5
		17	/4.F4
		18	/4.E2
		18	/4.E2
		19	/4.E3
		19	/4.E3
		20	/4.E6
		20	/4.E5
		21	/4.D4
		22	/4.C2
		22	/4.C2
		23	/4.C3
		23	/4.C3
		24	/4.C4
		24	/4.C4
		25	/4.B5
		25	/4.C6
		25	/4.C6
		26	/4.B3
		27	/4.A4
		N5	/5.E13
		N5	/5.F13
		N5	/5.G13
		N5	/5.H13
		R16	/5.I10
		X00	/5.H4
		X01	/5.G4
		X02	/5.F4
		X03	/5.F4
		X04	/5.E3

Name: Default Cable
 Brand: Generic
 Model: Generic
 Cores: 1
 Area: 1.5
 Order No.:
 Supplier:
 Remarks:
 Price: 0

Name: Default Cable
 Brand: Generic
 Model: Generic
 Cores: 1
 Area: 1.5
 Order No.:
 Supplier:
 Remarks:
 Price: 0

Cable	Core Name	Wire	Location
		Y00	/5.G11
		Y01	/5.F11
		Y02	/5.F11
		Y03	/5.E11
		0v	/5.I9
		0v	/5.C3
		0v	/5.F2
		0v	/5.F2
		0v	/5.F3
		0v	/5.G3
		0v	/5.G3
		0v	/5.H3
		0v	/5.I4
		24v	/5.I9
		24v	/5.C1
		24v	/5.F1
		24v	/5.I3
		33	/5.D9
		34	/5.D9
		35	/5.C9

Wire	Location	Cable	Core No.	Core Name	Reference	Location	Pin Name	Reference	Location	Pin Name
AI+	/2.E11				Inv1	/2.D10	AI+	Res1	/2.E12	3
AO+	/2.E12				Inv1	/2.D10	AO+	P1	/2.D13	1
AO-	/2.D12				Inv1	/2.D10	AO-	P1	/2.D13	2
N	/2.F1				X1-1	/2.J1		F1	/3.I2	3
N	/3.I1				F1	/3.I2	3	F2	/3.G2	3
N	/3.G1				F2	/3.G2	3	F3	/3.E2	3
N	/3.E1				F3	/3.E2	3	MCB6	/3.C2	3
N	/3.C1				X1-1	/2.J1		MCB6	/3.C2	3
N1	/3.I3				F1	/3.I2	4	R1	/3.I4	23
N2	/3.G3				F2	/3.G2	4	R2	/3.G4	23
N3	/3.E3				F3	/3.E2	4	R3	/3.E4	23
N4	/3.C3				MCB6	/3.C2	4	SS1	/3.C4	23
					X3-2	/3.C3				
N5	/3.C7				SS1	/3.C4	24	TC1	/3.H8	N
					X3-4	/3.C4				
N5	/3.B8				TC1	/3.H8	N	G1	/3.B8	N
N5	/3.I14				R1	/3.I13	A2	R2	/3.H13	A2
N5	/3.I14				R2	/3.H13	A2	R3	/3.G13	A2
N5	/3.H14				R3	/3.G13	A2	X3-10	/3.F14	
N5	/3.G14				X3-10	/3.F14		X3-12	/3.E14	
N5	/3.E14				X3-12	/3.E14		C1	/4.I6	A2
N5	/4.J7				C1	/4.I6	A2	PL1	/4.I6	X2
N5	/4.I7				PL1	/4.I6	X2	PL2	/4.H6	X2
					X3-18	/4.I7				
N5	/4.H7				PL2	/4.H6	X2	C2	/4.G6	A2
					X3-20	/4.H7				
N5	/4.H7				C2	/4.G6	A2	PL3	/4.G6	X2
N5	/4.G7				PL3	/4.G6	X2	PL4	/4.F6	X2
					X3-26	/4.G7				
N5	/4.F7				PL4	/4.F6	X2	C3	/4.E6	A2
					X3-28	/4.F7				
N5	/4.F7				C3	/4.E6	A2	PL5	/4.E6	X2
N5	/4.E7				PL5	/4.E6	X2	PL6	/4.D6	X2
					X3-34	/4.E7				
N5	/4.D7				PL6	/4.D6	X2	C4	/4.C6	A2
					X3-36	/4.D7				
N5	/4.D7				C4	/4.C6	A2	PL7	/4.C6	X2
N5	/4.C7				PL7	/4.C6	X2	PL8	/4.A6	X2
					X3-46	/4.C7				
N5	/4.B7				PL8	/4.A6	X2	PL9	/5.G13	X2
					X3-48	/4.A7				
N5	/5.H13				PL9	/5.G13	X2	R4	/5.F13	A2
N5	/5.G13				R4	/5.F13	A2	R5	/5.E13	A2
N5	/5.F13				R6	/5.E13	A2	R5	/5.E13	A2
N5	/5.E13				SS1	/3.C4	24	R6	/5.E13	A2
N5	/3.F14	1 Core	1	1	Y1	/3.F13	A2	X3-10	/3.F14	
N5	/3.E14	1 Core	1	1	Sol1	/3.E13	A2	X3-12	/3.E14	
R1	/2.J1				X1-2	/2.J1		ISO1	/2.I1	1
R2	/2.H1				ISO1	/2.H1	2	MCB1	/2.H1	1
R3	/2.D1				MCB1	/2.H1	2	MCB2	/2.G2	1
R3	/2.G1				MCB2	/2.G2	1	MCB3	/2.E2	1
R3	/2.E1				MCB3	/2.E2	1	MCB4	/2.C2	1
R3	/2.C1				MCB5	/2.I10	1	MCB4	/2.C2	1
R3	/2.I9				MCB5	/2.I10	1	Inv1	/2.D10	L1/R
R3	/2.G9				Inv1	/2.D10	L1/R	F1	/3.I2	1
R3	/3.I1				F1	/3.I2	1	MCB6	/3.C2	1
R3	/3.C1				MCB1	/2.H1	2	MCB6	/3.C2	1
R4	/2.G3				MCB2	/2.G2	2	C1	/2.G4	1
R5	/2.G4				C1	/2.G4	2	TOR1	/2.G5	1
R6	/2.E3				MCB3	/2.E2	2	C2	/2.E4	1
R7	/2.E4				C2	/2.E4	2	TOR2	/2.E5	1
R8	/2.C3				MCB4	/2.C2	2	C3	/2.C4	1
R9	/2.C4				C3	/2.C4	2	TOR3	/2.C5	1
R10	/2.I10				MCB5	/2.I10	2	C4	/2.I11	1
R11	/2.I12				C4	/2.I11	2	TOR4	/2.I12	1
R12	/3.I3				F1	/3.I2	2	R1	/3.I4	13
R13	/3.C3				MCB6	/3.C2	2	SS1	/3.C4	13
					X3-1	/3.C3				
R14	/3.C4				SS1	/3.C4	14	ES1	/3.C5	11
					X3-3	/3.C4				

Wire	Location	Cable	Core No.	Core Name	Reference	Location	Pin Name	Reference	Location	Pin Name
R15	/3.C6				X3-5	/3.C5				
					ES1	/3.C5	12	ES2	/3.C6	11
					X3-6	/3.C6				
					X3-7	/3.C6				
R16	/3.I7				ES2	/3.C6	12	TC1	/3.H8	L
R16	/3.I7				TC1	/3.H8	1a	R4	/3.F8	13
R16	/3.G7				R4	/3.F8	13	R6	/3.E8	13
R16	/3.E7				TC1	/3.H8	1a	R6	/3.E8	13
R16	/3.C8				TC1	/3.H8	L	G1	/3.B8	L
R16	/3.C8				ES2	/3.C6	12	G1	/3.B8	L
					X3-8	/3.C7				
R16	/4.J1				TOR1	/4.I1	11	TOR1	/4.H1	13
R16	/4.I1				TOR1	/4.H1	13	TOR2	/4.G1	11
R16	/4.H1				TOR2	/4.G1	11	TOR2	/4.F1	13
R16	/4.G1				TOR2	/4.F1	13	TOR3	/4.E1	11
R16	/4.F1				TOR3	/4.E1	11	TOR3	/4.D1	13
R16	/4.E1				TOR3	/4.D1	13	TOR4	/4.C1	11
R16	/4.D1				TOR4	/4.C1	11	TOR4	/4.A1	13
R16	/4.B1				TOR4	/4.A1	13	PLC1	/5.E8	COM
R16	/5.I10				ES2	/3.C6	12	PLC1	/5.E8	COM
S1	/2.J1				X1-3	/2.J1		ISO1	/2.I1	3
S2	/2.H1				ISO1	/2.I1	4	MCB1	/2.H1	3
S3	/2.D1				MCB1	/2.H1	4	MCB2	/2.G2	3
S3	/2.G1				MCB2	/2.G2	3	MCB3	/2.E2	3
S3	/2.E1				MCB3	/2.E2	3	MCB4	/2.C2	3
S3	/2.C1				MCB5	/2.I10	3	MCB4	/2.C2	3
S3	/2.I9				MCB5	/2.I10	3	Inv1	/2.D10	L2/S
S3	/2.G9				Inv1	/2.D10	L2/S	F2	/3.G2	1
S3	/3.G2				MCB1	/2.H1	4	F2	/3.G2	1
S4	/2.G3				MCB2	/2.G2	4	C1	/2.G4	3
S5	/2.G4				C1	/2.G4	4	TOR1	/2.G5	3
S6	/2.E3				MCB3	/2.E2	4	C2	/2.E4	3
S7	/2.E4				C2	/2.E4	4	TOR2	/2.E5	3
S8	/2.C3				MCB4	/2.C2	4	C3	/2.C4	3
S9	/2.C4				C3	/2.C4	4	TOR3	/2.C5	3
S10	/2.I10				MCB5	/2.I10	4	C4	/2.I11	3
S11	/2.I12				C4	/2.I11	4	TOR4	/2.I12	3
S12	/3.G3				F2	/3.G2	2	R2	/3.G4	13
T1	/2.J1				X1-4	/2.J1		ISO1	/2.I1	5
T2	/2.H1				ISO1	/2.I1	6	MCB1	/2.H1	5
T3	/2.D1				MCB1	/2.H1	6	MCB2	/2.G2	5
T3	/2.G2				MCB2	/2.G2	5	MCB3	/2.E2	5
T3	/2.E2				MCB3	/2.E2	5	MCB4	/2.C2	5
T3	/2.C2				MCB5	/2.I10	5	MCB4	/2.C2	5
T3	/2.H9				MCB5	/2.I10	5	Inv1	/2.D10	L3/T
T3	/2.F9				Inv1	/2.D10	L3/T	F3	/3.E2	1
T3	/3.E2				MCB1	/2.H1	6	F3	/3.E2	1
T4	/2.G3				MCB2	/2.G2	6	C1	/2.G4	5
T5	/2.G4				C1	/2.G4	6	TOR1	/2.G5	5
T6	/2.E3				MCB3	/2.E2	6	C2	/2.E4	5
T7	/2.D4				C2	/2.E4	6	TOR2	/2.E5	5
T8	/2.C3				MCB4	/2.C2	6	C3	/2.C4	5
T9	/2.B4				C3	/2.C4	6	TOR3	/2.C5	5
T10	/2.H10				MCB5	/2.I10	6	C4	/2.I11	5
T11	/2.H12				C4	/2.I11	6	TOR4	/2.I12	5
T12	/3.E3				F3	/3.E2	2	R3	/3.E4	13
U1	/2.G6				TOR1	/2.G5	2	X2-1	/2.G6	
U1	/2.G6	Fan Motor 1	1	Red	X2-1	/2.G6		M1	/2.G7	U1
U2	/2.E6				TOR2	/2.E5	2	X2-4	/2.E6	
U2	/2.E6	Fan Motor 2	1	Red	X2-4	/2.E6		M2	/2.E7	U1
U3	/2.C6				TOR3	/2.C5	2	X2-7	/2.C6	
U3	/2.C6	Fan Motor 3	1	Red	X2-7	/2.C6		M3	/2.C7	U1
U4	/2.I13				TOR4	/2.I12	2	X2-10	/2.I13	
U4	/2.I13	Feeder Motor	1	Red	X2-10	/2.I13		M4	/2.I14	U1
U5	/2.G11				Inv1	/2.D10	T1/U	X2-13	/2.G11	
U5	/2.G12	Main Conveyor	1	Red	X2-13	/2.G11		M5	/2.F14	U1
U6	/3.I5	1 Core	1	1	X2-16	/3.I5		H1	/3.I5	A1
U6	/3.I4				R1	/3.I4	14	X2-16	/3.I5	
U7	/3.G4				R2	/3.G4	14	X2-18	/3.G5	
U7	/3.G5	1 Core	1	1	X2-18	/3.G5		H2	/3.G5	A1

Wire	Location	Cable	Core No.	Core Name	Reference	Location	Pin Name	Reference	Location	Pin Name
U8	/3.E4	1 Core	1	1	R3	/3.E4	14	X2-20	/3.E5	A1
U8	/3.E5				X2-20	/3.E5	H3	/3.E5		
V1	/2.G6	Fan Motor 1	2	Yellow	TOR1	/2.G5	4	X2-2	/2.G6	
V1	/2.G6				X2-2	/2.G6	M1	/2.G7	V1	
V2	/2.E6	Fan Motor 2	2	Yellow	X2-5	/2.E6		M2	/2.E7	V1
V2	/2.E6				TOR2	/2.E5	4	X2-5	/2.E6	
V3	/2.C6	Fan Motor 3	2	Yellow	TOR3	/2.C5	4	X2-8	/2.C6	
V3	/2.C6				X2-8	/2.C6	M3	/2.C7	V1	
V4	/2.I13	Feeder Motor	2	Yellow	TOR4	/2.I12	4	X2-11	/2.I13	
V4	/2.I13				X2-11	/2.I13	M4	/2.I14	V1	
V5	/2.G11	Main Conveyor	2	Yellow	Inv1	/2.D10	T2/V	X2-14	/2.G11	V1
V5	/2.F12				X2-14	/2.G11	M5	/2.F14	V1	
V6	/3.I6	1 Core	1	1	H1	/3.I5	A2	X2-17	/3.I6	
V6	/3.I5				R1	/3.I4	24	X2-17	/3.I6	
V7	/3.G5	1 Core	1	1	R2	/3.G4	24	X2-19	/3.G6	
V7	/3.G5				H2	/3.G5	A2	X2-19	/3.G6	
V8	/3.E5	1 Core	1	1	R3	/3.E4	24	X2-21	/3.E6	
V8	/3.E6				H3	/3.E5	A2	X2-21	/3.E6	
W1	/2.F6	Fan Motor 1	3	Blue	TOR1	/2.G5	6	X2-3	/2.F6	
W1	/2.F6				X2-3	/2.F6	M1	/2.G7	W1	
W2	/2.D6	Fan Motor 2	3	Blue	TOR2	/2.E5	6	X2-6	/2.D6	
W2	/2.D6				X2-6	/2.D6	M2	/2.E7	W1	
W3	/2.B6	Fan Motor 3	3	Blue	TOR3	/2.C5	6	X2-9	/2.B6	
W3	/2.B6				X2-9	/2.B6	M3	/2.C7	W1	
W4	/2.H13	Feeder Motor	3	Blue	TOR4	/2.I12	6	X2-12	/2.H13	
W4	/2.H13				X2-12	/2.H13	M4	/2.I14	W1	
W5	/2.F11	Main Conveyor	3	Blue	Inv1	/2.D10	T3/W	X2-15	/2.F11	
W5	/2.F12				X2-15	/2.F11	M5	/2.F14	W1	
X00	/5.H4				PX1	/5.G3	14	PLC1	/5.F6	X00
X01	/5.G4				X4-1	/5.H4		PLC1	/5.F6	X01
X02	/5.F4				PX2	/5.G3	14	PLC1	/5.F6	X02
X03	/5.F4				X4-3	/5.G4		PLC1	/5.F6	X03
X04	/5.E3				SS3	/5.F3	14	PLC1	/5.F6	X04
Y00	/5.G11				X4-5	/5.F4		PLC1	/5.F6	X04
Y01	/5.F11				PB9	/5.E3	14	PLC1	/5.F6	X04
Y02	/5.F11				X4-7	/5.F4		PLC1	/5.F6	X04
Y03	/5.E11				S2	/5.F2	BK	PLC1	/5.F6	X04
0v	/3.B9				X4-13	/5.E2		PLC1	/5.E8	Y00
0v	/5.F2				PL9	/5.G13	X1	PLC1	/5.E8	Y01
0v	/5.F2				R4	/5.F13	A1	PLC1	/5.E8	Y02
0v	/5.H3				R5	/5.E13	A1	PLC1	/5.E8	Y03
0v	/5.G3				R6	/5.E13	A1	PLC1	/5.E8	Y03
0v	/5.G3				G1	/3.B8	-	S2	/5.F2	BL1
0v	/5.F3				S2	/5.F2	BL1	S2	/5.F2	BL2
0v	/5.14				X4-10	/5.F2	BL2	PX1	/5.G3	13
0v	/2.E10				S2	/5.F2	BL2	PX1	/5.G3	13
0v	/2.E11				X4-12	/5.F2		PX2	/5.G3	13
10v	/2.F11				PX2	/5.G3	13	PX2	/5.G3	13
10	/4.I2				X4-2	/5.H3		SS3	/5.F3	13
11	/4.I3				PX2	/5.G3	13	PB9	/5.E3	13
11	/4.I3				X4-4	/5.C3		PLC1	/5.F6	0Vdc
12	/4.I5				SS3	/5.F3	13	PLC1	/5.E8	0Vdc
12	/4.I6				X4-6	/5.F3		PLC1	/5.E8	0Vdc
					PB9	/5.E3	13	PLC1	/5.E8	0Vdc
					X4-8	/5.F3		PLC1	/5.E8	0Vdc
					PLC1	/5.F6	0Vdc	PLC1	/5.E8	0Vdc
					G1	/3.B8	-	PLC1	/5.E8	0Vdc
					Inv1	/2.D10	0v	Inv1	/2.D10	A1-
					Inv1	/2.D10	A1-	Res1	/2.E12	2
					Inv1	/2.D10	+10v	Res1	/2.E12	1
					TOR1	/4.I1	12	PB1	/4.I2	13
					X3-13	/4.I2				
					PB1	/4.I2	13	C1	/4.I2	13
					PB1	/4.I2	14	C1	/4.I2	14
					PB1	/4.I2	14	PB2	/4.I4	11
					X3-14	/4.I3				
					X3-15	/4.I3				
					PB2	/4.I4	12	C1	/4.I6	A1
					X3-16	/4.I4				
					C1	/4.I6	A1	PL1	/4.I6	X1

Wire	Location	Cable	Core No.	Core Name	Reference	Location	Pin Name	Reference	Location	Pin Name
13	/4.H4				X3-17	/4.I6				
14	/4.G2				TOR1	/4.H1	14	PL2	/4.H6	X1
14	/4.G2				X3-19	/4.H6				
14	/4.G2				TOR2	/4.G1	12	PB3	/4.G2	13
14	/4.G2				X3-21	/4.G2				
15	/4.G3				PB3	/4.G2	13	C2	/4.G2	13
15	/4.G3				PB3	/4.G2	14	C2	/4.G2	14
15	/4.G3				PB3	/4.G2	14	PB4	/4.G4	11
16	/4.G5				X3-22	/4.G3				
16	/4.G6				X3-23	/4.G3				
16	/4.G6				PB4	/4.G4	12	C2	/4.G6	A1
17	/4.F4				X3-24	/4.G4				
17	/4.F4				C2	/4.G6	A1	PL3	/4.G6	X1
18	/4.E2				X3-25	/4.G6				
18	/4.E2				TOR2	/4.F1	14	PL4	/4.F6	X1
18	/4.E2				X3-27	/4.F6				
18	/4.E2				TOR3	/4.E1	12	PB5	/4.E2	13
19	/4.E3				X3-29	/4.E2				
19	/4.E3				PB5	/4.E2	13	C3	/4.E2	13
19	/4.E3				PB5	/4.E2	14	C3	/4.E2	14
19	/4.E3				PB5	/4.E2	14	PB6	/4.E4	11
20	/4.E5				X3-30	/4.E3				
20	/4.E5				X3-31	/4.E3				
20	/4.E5				PB6	/4.E4	12	C3	/4.E6	A1
20	/4.E5				X3-32	/4.E4				
20	/4.E6				C3	/4.E6	A1	PL5	/4.E6	X1
20	/4.E6				X3-33	/4.E6				
21	/4.D4				TOR3	/4.D1	14	PL6	/4.D6	X1
22	/4.C2				X3-35	/4.D6				
22	/4.C2				TOR4	/4.C1	12	SS2	/4.C2	13
22	/4.C2				X3-37	/4.C2				
23	/4.C3				SS2	/4.C2	13	SS2	/4.B2	11
23	/4.C3				X3-39	/4.B2				
23	/4.C3				SS2	/4.C2	14	PB7	/4.C4	13
23	/4.C3				X3-38	/4.C3				
23	/4.C3				X3-41	/4.C3				
24v	/3.B9				PB7	/4.C4	13	C4	/4.C4	13
24v	/5.G1				G1	/3.B8	+	S2	/5.F2	BR1
24v	/5.F1				S2	/5.F2	BR1	S2	/5.F2	BR2
24v	/5.F1				X4-9	/5.F1				
24v	/5.13				S2	/5.F2	BR2	PLC1	/5.F6	24Vdc
24v	/5.19				X4-11	/5.E1				
24	/4.C4				PLC1	/5.F6	24Vdc	PLC1	/5.E8	24Vdc
24	/4.C4				G1	/3.B8	+	PLC1	/5.E8	24Vdc
24	/4.C4				PB7	/4.C4	14	C4	/4.C4	14
24	/4.C4				PB7	/4.C4	14	PB8	/4.C5	11
25	/4.B5				X3-42	/4.C4				
25	/4.C6				X3-43	/4.C5				
25	/4.C6				R5	/4.B4	14	PB8	/4.C5	12
25	/4.C6				PB8	/4.C5	12	C4	/4.C6	A1
26	/4.B3				X3-44	/4.C6				
26	/4.B3				C4	/4.C6	A1	PL7	/4.C6	X1
26	/4.B3				X3-45	/4.C6				
26	/4.B3				SS2	/4.B2	12	R5	/4.B4	13
26	/4.B3				X3-40	/4.B3				
27	/4.A4				TOR4	/4.A1	14	PL8	/4.A6	X1
27	/4.A4				X3-47	/4.A6				
28	/3.I11				R1	/3.I13	A1	TC1	/3.H8	1b
28	/3.I13				R1	/3.I13	A1	R2	/3.H13	A1
28	/3.H13				R2	/3.H13	A1	R3	/3.G13	A1
29	/3.H9				TC1	/3.H8	b	X4-14	/3.H9	
29	/3.H9				TO1	/3.G10	+	X4-14	/3.H9	
30	/3.G9				TC1	/3.H8	B	X4-15	/3.G9	
30	/3.G9				TO1	/3.G10	-	X4-15	/3.G9	
31	/3.F10				X3-9	/3.F13		R4	/3.F8	14
31	/3.F13	1 Core	1	1	X3-9	/3.F13		Y1	/3.F13	A1
32	/3.E10				X3-11	/3.E13		R6	/3.E8	14
32	/3.E13	1 Core	1	1	X3-11	/3.E13		Sol1	/3.E13	A1
33	/2.D11				Inv1	/2.D10	COM	PLC1	/5.E8	COM
34	/2.D11				Inv1	/2.D10	FWD	PLC1	/5.E8	Y04

Wire	Location	Cable	Core No.	Core Name	Reference	Location	Pin Name	Reference	Location	Pin Name
35	/2.C11				Inv1	/2.D10	REV	PLC1	/5.E8	Y05

J
I
H
G
F
E
D
C
B
A